

Composting Bins You Can Build

Composting Bins You Can Build

The following composting equipment and bins are designed for easy home construction using a moderate amount of skill, effort, time and some common tools (see below). In many cases, the materials listed can be substituted with others more preferable or more readily available. Also, the basic designs can often be built to different dimensions from those illustrated, and the construction sequence can also be varied to use different joints or methods of fastening.

Common Tools

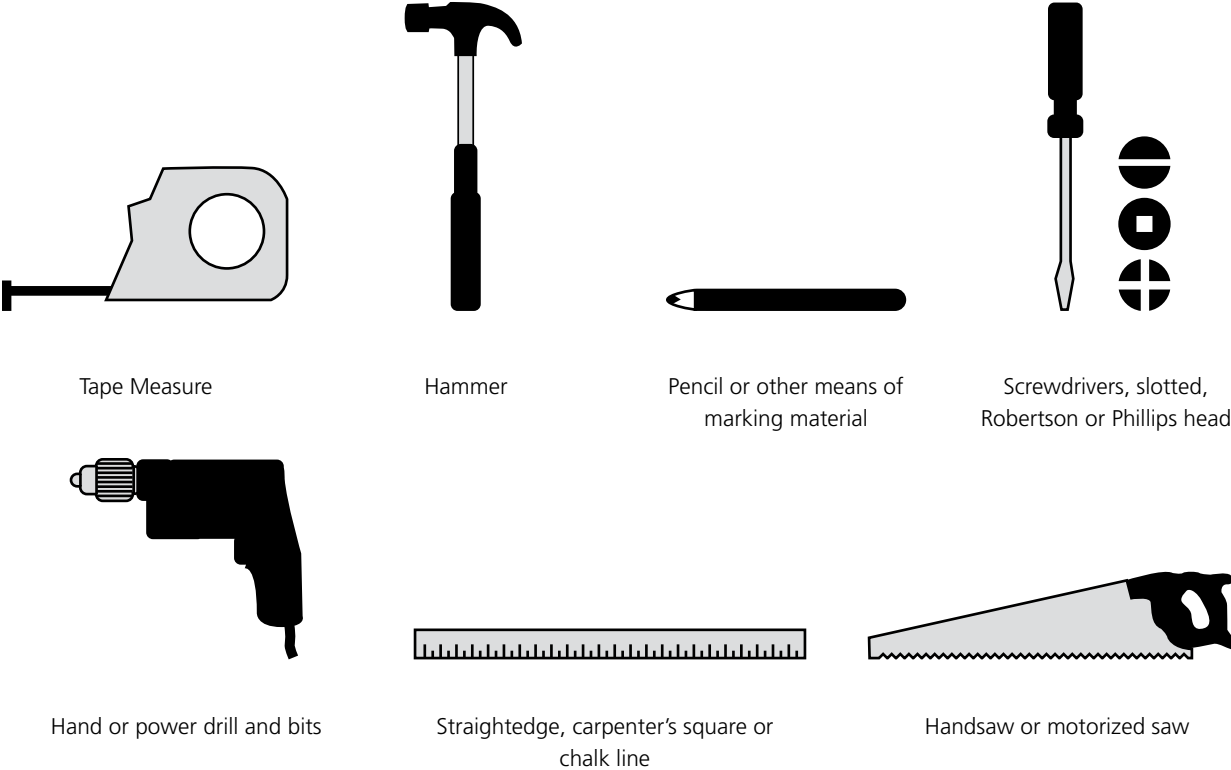

note Proper protective equipment such as work gloves, eye goggles and ear defenders should be worn when using tools.

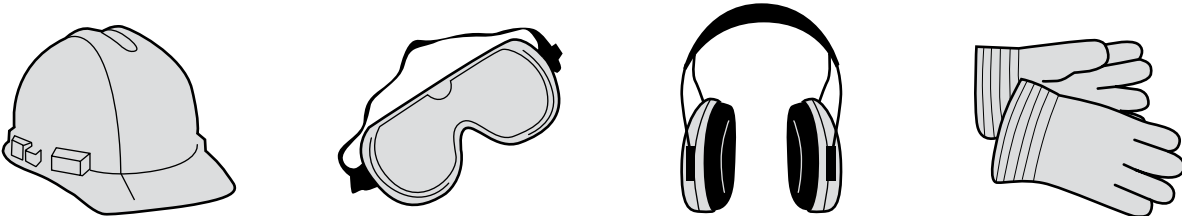

SINGLE COMPARTMENT COMPOSTER

This single compartment bin serves to hold and confine a compost pile. Access for pile turning and removing finished compost is via the loose front boards which are fit into the slots formed by four of the upright posts. A sliding cross bar at the top prevents the sides from spreading. An optional removable top can be made for the unit with a sheet

of heavy plastic stapled to the backboards and the cross bar.

This design is an adaptation of the New Zealand Hot Box developed by Sir Albert Howard, a noted pioneer composting researcher. It should be sited on a level piece of ground.

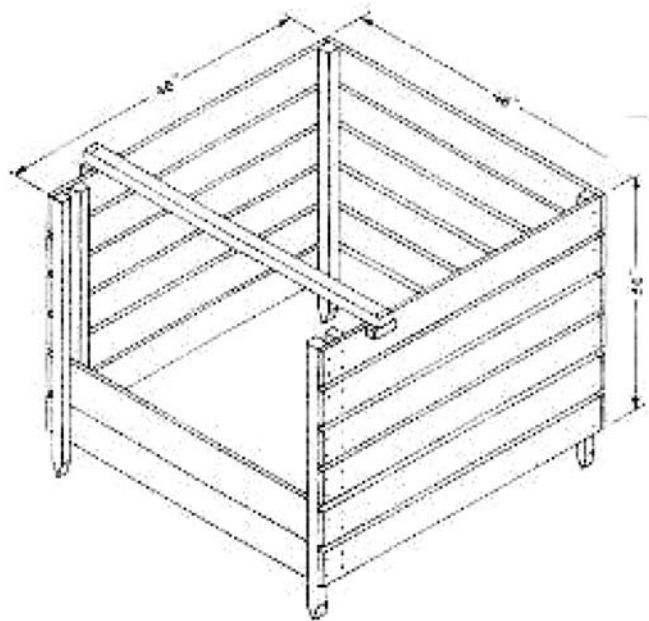

Specialized Tools

- hatchet
- Power or hand drill with 1/8" twist bit

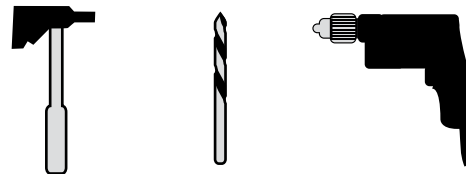

List of Materials

- 6 3'-6" 2x2s (posts)
- 1 4'-9" 2x2s
- 24 4' 1x6s
- 96 1-1/2" No. 10 galvanized wood screws
- 4 2-1/2" No. 10 galvanized wood screws

Construction Sequence

1. Posts. Shave down the ends of the six 3- 1/2' long 2x2 posts to a point with a hatchet. At the location where the composter will be sited, pound in the four corner posts vertically to a depth of six inches into the soil. The posts should be spaced apart (outside of post to outside of post) 4 feet from front to rear and 3 feet 10 1/2" from side to side. Pound in the remaining two posts to the same soil depth immediately behind the front posts. Allow a one-inch gap between the posts for the front boards.

2. Sides and Rear. Starting at the bottom with a 1/2" gap, attach six 1x6 boards to the side posts on each side. Use two 1-1/2" screws per post per board. Pilot drill the screw holes first with a 1/8" bit. Allow

a 1/2" vertical gap between the boards for airflow. After the side boards have been attached, screw and attach six 1x6 boards to the rear of the unit. Again use two 1-1/2" screws per post per board.

3. Front. Fit the remaining six 1x6 boards loosely into the slots formed by the four front posts.

4. Cross Bar. Cut two 3" long pieces from the remaining 4'-9" 2x2. Turn the pieces and attach one under each end of the 2x2 with two 2-1/2" screws. Pilot drill the screw holes first with a 1/8" bit to prevent the wood from splitting. Fit the completed bar across the top of the unit at the front.

tip

Too many grass clippings in your bin can cause odours and methane problems. Mix them well with brown material before adding them to the bin. Better yet – try Grasscycling!

COMPOST SCREEN

A compost screen is a handy device for separating finely textured finished compost for immediate use. The remaining coarse materials such as twigs, large lumps and nut shells can be returned to the compost pile for further breakdown.

A compost screen can be constructed and sized to suit individual requirements and preferences.

This design measures 20 inches by 18 inches and is adapted from one prepared by the Recycling Council of Ontario. A number of mesh sizes can be used depending on the end use. Finer, ¼-inch mesh is suitable for finished compost to be used as lawn top dressing or in a seed starter mix.

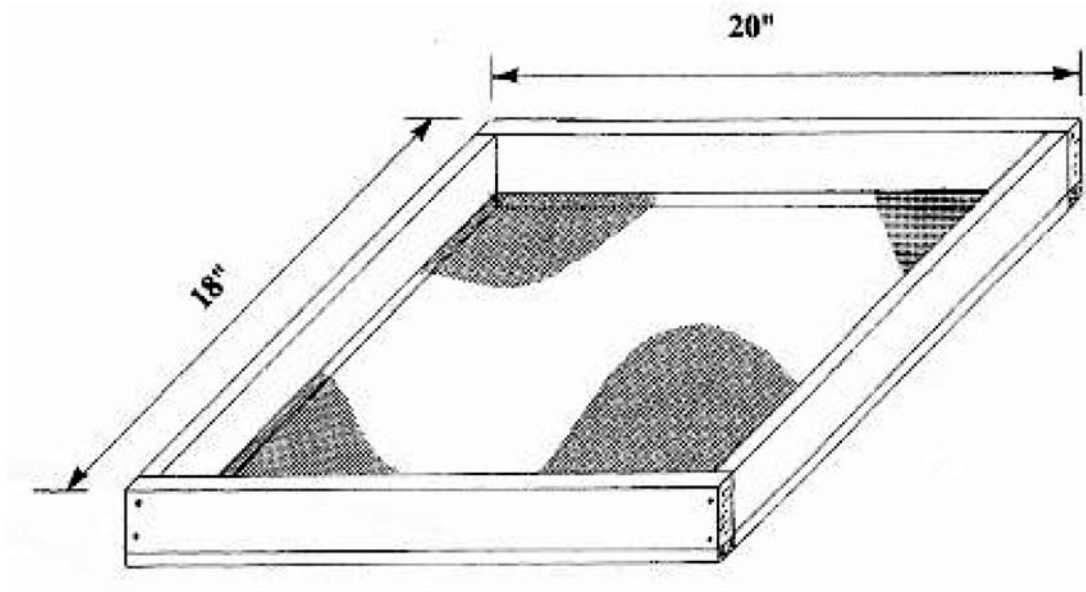

Specialized Tools

- tinsnips
- staple gun or power stapler

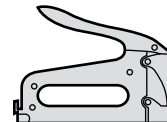
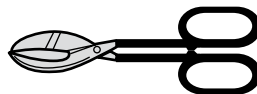

List of Materials

- 6' 2x4
- 6' 1x2
- 2'x2' piece of ¼" galvanized wire mesh
- carpenter's glue
- 3" common nails
- 1-1/2" common nails

Construction Sequence

1. Cut the 6' 2x4 and 6' 1x2 each into four pieces, two at 20" and two at 15". With the 2x4 pieces on edge, form them into a rectangular butt joint frame and connect the frame together using carpenter's glue and two 3" nails at each joint. If required, the joints can be made more secure with screws and corner braces.

2. Cut the galvanized mesh to fit the frame and staple the two together. Use a staple every 4 inches around the edge. Tension the mesh so that it will not sag when filled with compost.

3. Once the mesh is secure on the bottom of the frame, nail the 1x2 strapping pieces over top of it.

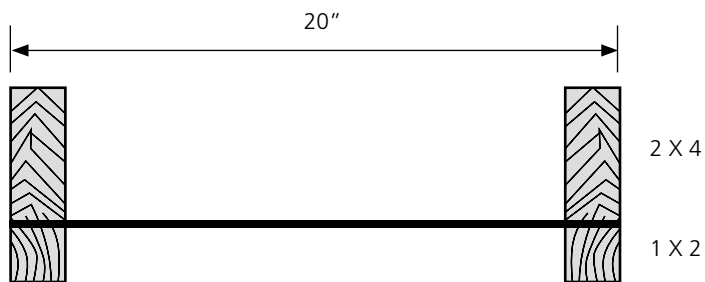

tip

Adjust the size of your screen to fit securely over your wheel barrow.

COMPOST TEA CONTAINER

One use of finished compost is to make a liquid plant watering solution or “compost tea.” Macro and micronutrients are most available to plants when in a soluble form.

Compost tea can be simply made by suspending and steeping a bag of finished compost in a drum of water for a few days. The bag should be of a pervious material such as burlap.

This design for a compost tea container utilizes a plastic barrel with a tap installed at the bottom. Variations of it can be found in both *Let it Rot* and *The Rodale Guide to Composting*, available at your local library.

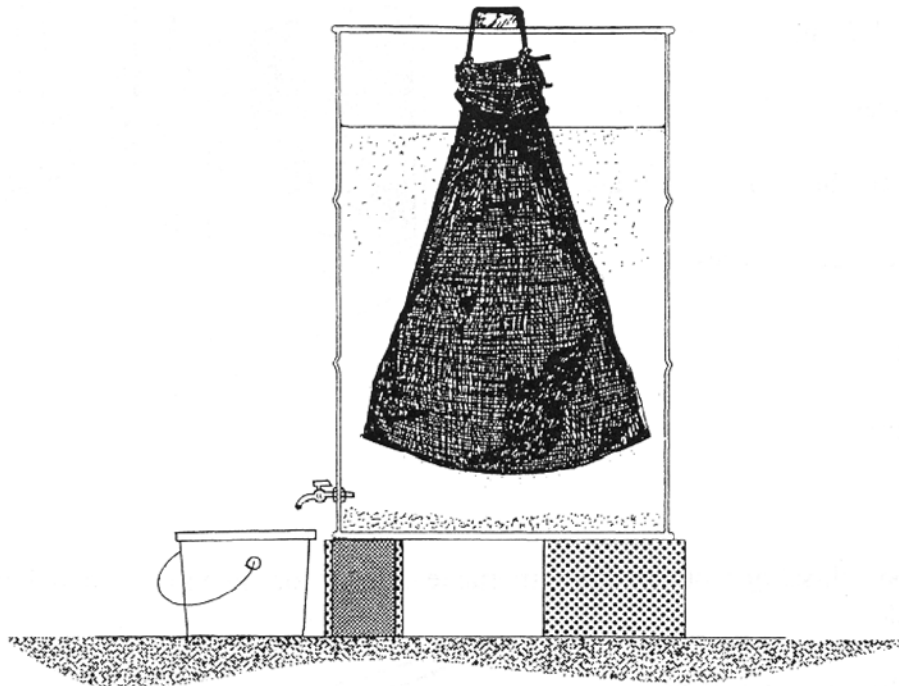

Specialized Tools

- hand or power drill with a $\frac{3}{4}$ -inch or other size spade bit EXACTLY equal to the outside diameter of the tap

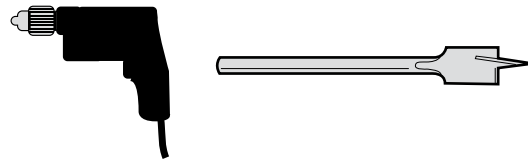

List of Materials

- 1 45-imperial-gallon plastic barrel
- 1 ½" plastic or metal tap
- 1 3' piece of 2x4
- 2 8" concrete blocks
- silicone sealant



Construction Sequence

1. Cut the top off the plastic barrel. Set the barrel on top of the concrete blocks.

2. Place the tap near the bottom of the barrel. Set it high enough so that any sludge collecting or settling at the bottom will not clog the tap, yet high enough so that a pail or watering can will fit it (see illustration).

3. Drill the hole for the tap through the side of the barrel, install the tap and seal it with silicone caulk. An exact or very close tolerance-size hole is important since both the tap and barrel will likely expand and contract at different rates with ambient temperature, and most caulking materials are not flexible enough to withstand this.

tip

Compost tea is best used within a day or two. For smaller batches use a 20 litre pail.

PORTABLE COMPOSTER

Portable compost bins serve to temporarily confine a pile. When it is time to turn the pile or withdraw finished compost from the bottom, the bin is taken apart and set up in an adjacent location in the yard. The partially composted material from the top of the old pile is then forked over into the empty bin, leaving the finished compost at the bottom for use.

Portable compost bins can be made from old wooden pallets lashed together, or a roll of wire or snow fencing. This particular version is made from hardware cloth stretched over four wooden lap jointed frames. The design was originally developed for the Community Composting Education Program in Seattle, Washington.

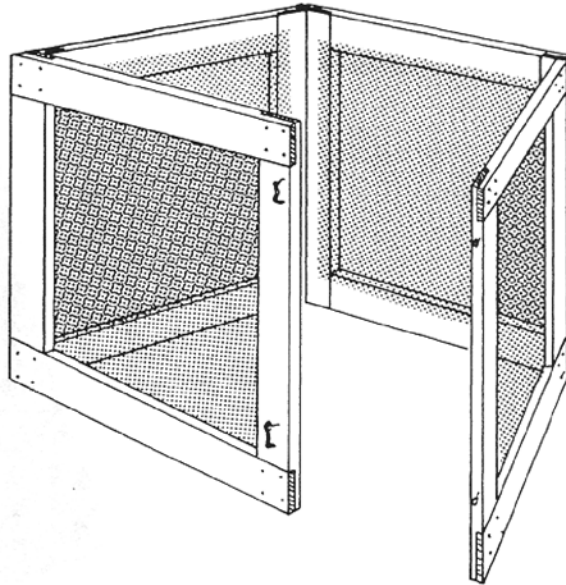

Specialized Tools

- tinsnips
- hammer and wood chisel or motorized saw (portable circular, or table saw or radial arm saw) with a dado blade
- power or hand drill with a 1/8" bit
- staple gun or power stapler c/w staples

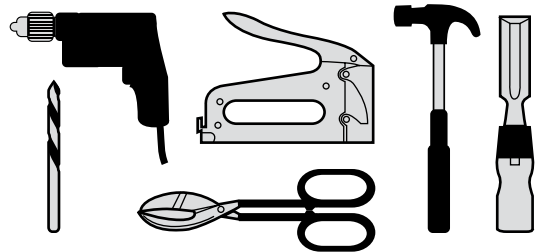

List of Materials

- 4 12' 2x4s
- 12 36" wide, 1/2" mesh hardware cloth
- 100 1-1/2" galvanized No. 8 screws
- 4 3" galvanized butt door hinges and screws
- 4 hook and eye gate latches
- carpenter's glue

Construction Sequence

1. Cut each 12' 2x4 into 4 pieces 3' long for a total of 16 pieces.

2. Cut 3-1/2" wide by 3/4" lap cuts at the ends of the 16 pieces of wood. Ensure that the cuts are made on the same side of each piece. If using a handsaw and chisel, first cut a 3/4" groove 3-1/2" in from each end and a 1/2" groove midway into the end of the board. This will prevent it from splitting as the ends are chiseled out. If using a power saw, set the blade depth to 3/4" and make multiple passes until the material at each end is removed.

3. Make four lap jointed frames 3' square with the 16 boards. Connect each lap joint with carpenter's glue and four wood screws. Pilot drill the screw holes with an 1/8" bit first to prevent the board ends from splitting.

4. Cut the hardware cloth with tinsnips into four 3' square sections. Reinforce each edge by bending it back an inch. Centre each section of cloth onto a frame (with the bent edge down against the wood) and staple the two together with a staple every 4". Tension the cloth so that it will not sag when filled with compost.

5. Connect each pair of frames with two hinges. At the outside edge of each connected pair, attach the hook and eye gate latches so that the L-shaped sections will latch together (see illustration). For rain protection, a plastic tarp can be placed on top of the pile.



OTHER PORTABLE COMPOSTERS

Other portable bins can be made with rolls of wire mesh or snow fencing. The following two illustrations are adapted from design sheets prepared by the City of Regina.

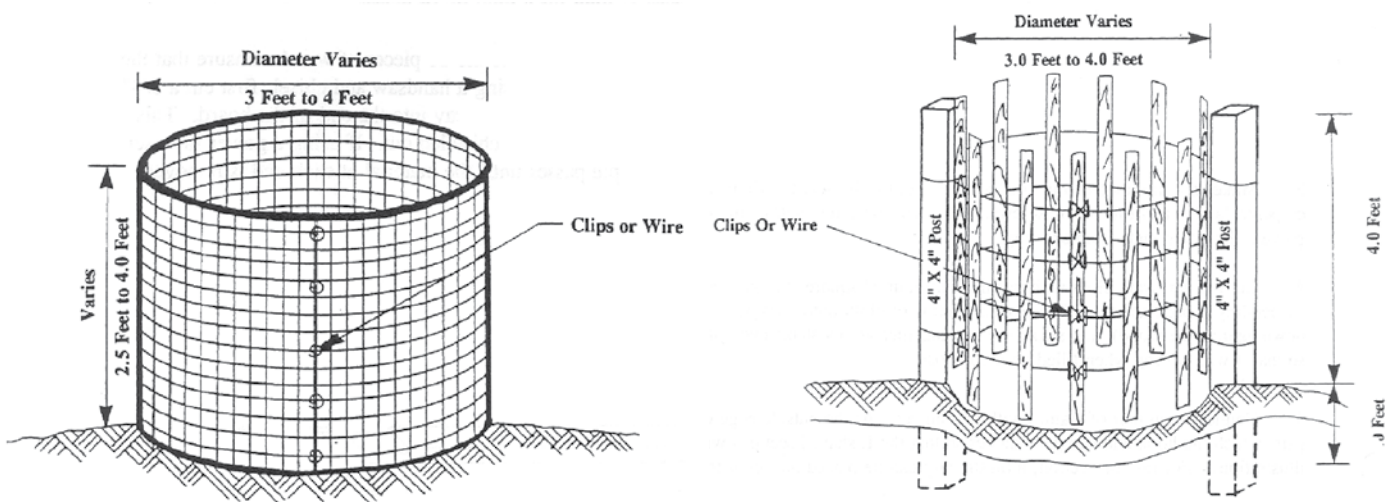

tip

The most common problem with compost not working is a dry pile. If your mesh composter dries out quickly, line the inside with cardboard and keep it damp.

MULTI-COMPARTMENT BIN

Multi-compartment composter bins allow for continuous processing of large amounts of material in batches. In a three-compartment composter, material can be turned and mixed between two of the compartments, with the third compartment used for curing and storage.

A three-compartment composter can be thought of as two additional sections attached to a single compartment

unit. A simple three-section unit can be constructed with seven discarded pallets lashed together. This particular design uses four identically constructed wood frames connected to common top and bottom boards, and with a single fibreglass lid. It is adapted from a design developed for the Community Composting Education Program in Seattle, Washington.

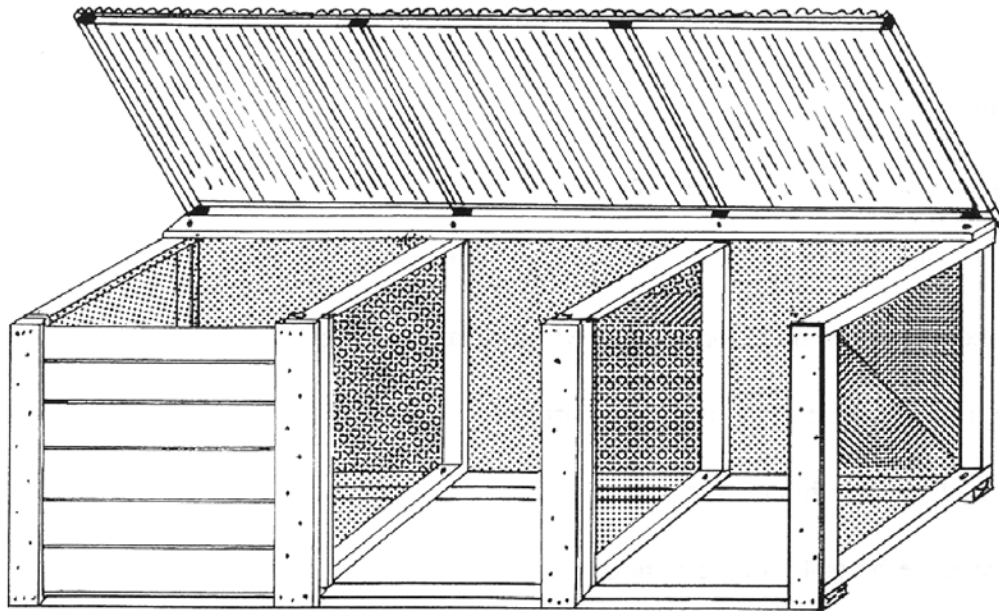

Specialized Tools

- tinsnips
- hand or power drill with 1/8" bit and 1/2" spade bit
- 3/4" socket wrench or adjustable wrench
- Carpenter's square
- staple gun or power stapler c/w staples

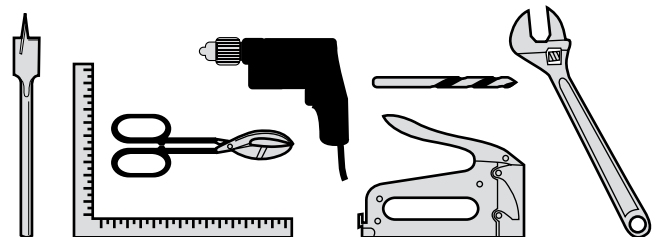

List of Materials

- 4 10' 2x4s
- 4 12' 2x4s or eight 6' 2x4s
- 4 10' 2x2s
- 2 6' 2x2
- 1 12' 2x6
- 9 6' 1x6s
- 22' 36" wide ½" mesh hardware cloth
- 10' x 2' sheet and one 8' x 2' sheet of 4 oz. corrugated fibreglass
- 40 gasketed aluminum nails for corrugated fibreglass roofing
- 3 8' lengths of wiggle moulding to fit corrugated fibreglass
- 2 3" zinc plated butt hinges for lid
- 12 ½" carriage bolts 4" long c/w nuts
- ½" flat washers for the bolts
- 12 ½" flat washers for the bolts
- 2 pounds of 3-1/2" galvanized nails
- 1/2 pound 2-1/2" galvanized casement (finishing) nails
- 4 flat 4" corner braces c/w screws
- 4 flat 3" T braces c/w screws
- carpenter's glue

Construction Sequence

1. Sides and Dividers. From the 12' or 6' 2x4s, cut eight pieces 36" long and eight pieces 32" long. Using two pieces of each on edge, form four butt-jointed frames 35" by 36" (see illustration). Connect each joint with nails and glue. Cut four 37"-long pieces of hardware cloth. Reinforce each edge by bending it back an inch. Centre each section of cloth onto a frame (with the bent edge down against the wood) and staple the two together with a staple every 4". Tension the cloth so that it will not sag when filled with compost.

2. Composter Frame. Cut the four 10' 2x4s into four 9' pieces. Lay two of them flat side down parallel to each other, 36" apart, outside to outside. Place the four frame pieces on the two boards, 36" dimension down. The two outside frames should be flush with the ends of the board and the two dividers should start at 35" in from each end. Mark the edges of each frame on both 9' long boards. Lay three of the frames aside.

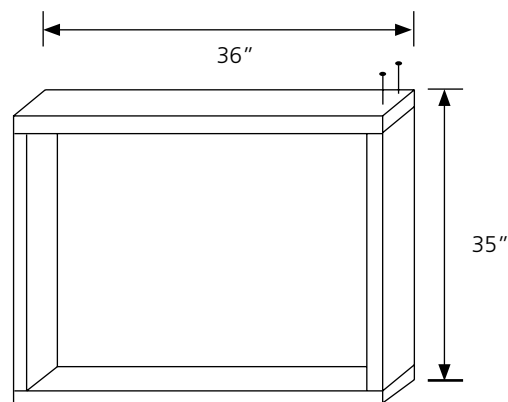

Starting with an outside frame, align it with its markings on a base and drill a ½" hole through the frame and baseboard into a piece of scrap wood. Secure the frame to the baseboard with a carriage bolt, washer and nut, but do not tighten. Feed the bolt through from the underside. Connect the frame to the other baseboard in the same manner and repeat for the remaining three frames.

Lay another 9' top board on top of the frames aligned with their rear outside edge and mark it in the same manner as the bottom boards. Keeping the frames aligned with their markings, drill a 1/2" hole through the top board and each frame in turn. Again, feed a carriage bolt down through each hole and secure the pieces together with a washer and nut.

Check the composter frame for squareness with a carpenter's square or by measuring the distance between outside corners. Adjust if required and tighten down all bolts with a socket or adjustable wrench. Connect the cloth to the frame with a staple every 4". Keep the tension on the cloth to prevent sagging.

3. Runners and Front Slats. Cut four pieces 36" long from the 12' 2x6. Nail two of them flush to the top and outside front edges of the frame. Nail the other two 2x6 pieces to the front of the inside dividers, keeping them centred and flush with the top.

From two 10' 2x2s, cut six pieces 35" long for back runners. Nail these to the frames parallel to the front runners with a 1" gap for slats.

For slats, cut all nine 6' 1x6 boards into pieces 30-1/2" long.

4. Fibreglass Lid. For the lid frame, cut the remaining 10' 2x2 into a 9' piece and the two 6' 2x2s into four pieces 32" long. Form these pieces and the remaining 9' 2x4 into a rectangular frame 9' by 37" as per the illustration. Check for squareness and then connect the frame together using corner braces for the outside corners and T braces for the interior dividers. Pilot drill the screw holes first to avoid splitting the wood.

Lay the lid frame, brace side down, on the compartment frame with the 2 x 4 piece at the rear. Attach the two together with the butt hinges. Pilot drill the screw holes first to avoid splitting the wood.

Cut the wiggle board moulding to fit the front and back of the lid frame. Position the pieces an inch in from the sides of the frame and nail them to the top of the lid frame with the 2-1/2" casement nails. Pilot drill the nail holes first to avoid splitting the wood.

Cut the 10' and 8' sheets of fibreglass into five pieces 37" long. Overlay each piece by at least one channel and position them on the top of the lid. Trim any overhangs at the ends to fit. Pre-drill the fibreglass and wiggle board moulding with one nail hole every third hump and connect with gasketed nails.

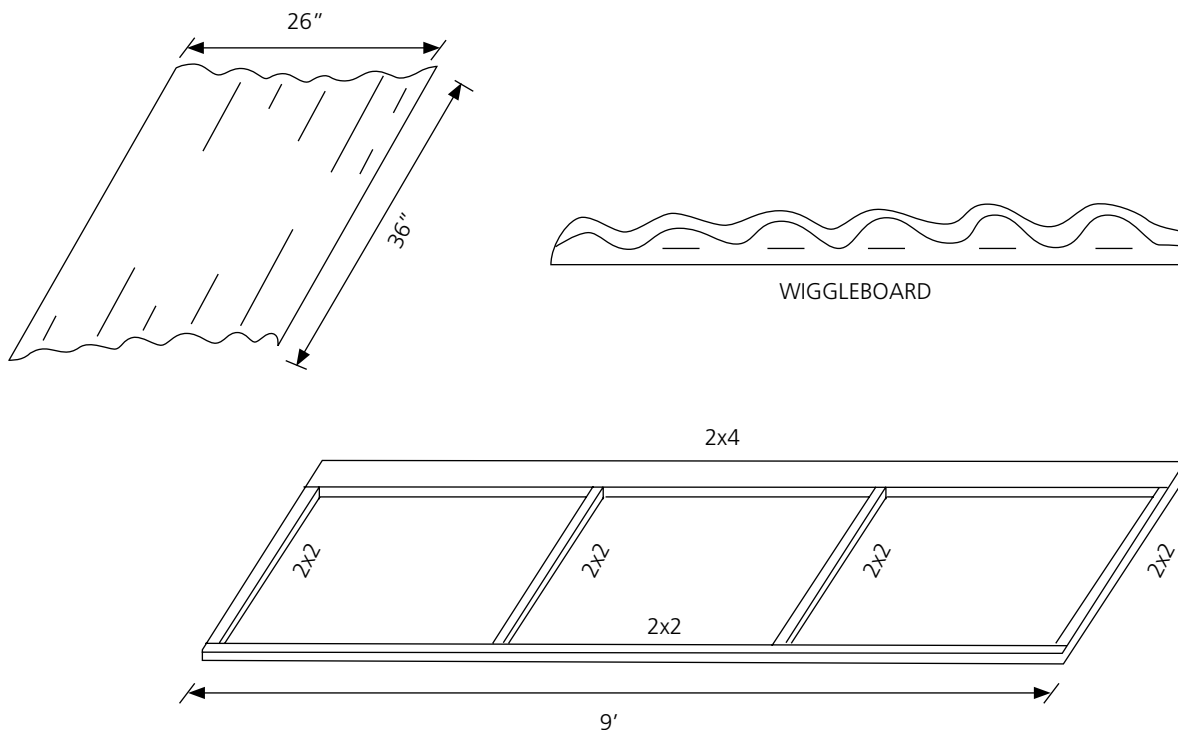

RECYCLED TIRE COMPOSTER

(Used with permission from Paul Farber, www.tirecrafting.com)

Get 8 firm tires, all the same size. Four will be used for your composter and the other 4 will be used for the storage of brown leaves. The larger the tires, the larger your piles will be. Cut out both sides two to three inches from the tread. Make a lid by bolting window screen between two sidewalls. Choose an area about 6 feet square, preferably in the sun, and close to water supply and garden.

In order to mix and aerate your compost pile using this method, try the following tips. Do not lift or carry units, but slide, lean, and roll them:

1. Pull first unit toward you, dumping the contents on the ground.
2. Place first unit in new location.
3. Fork contents into first unit.
4. Pull second unit off and dump contents.
5. Repeat sequence until all units are moved to new location.

Now compost is mixed and aerated. Don't forget to add water as you go to keep the pile nice and moist like a wrung out sponge. Tires hold the moisture extremely well so be careful not to over water the pile.

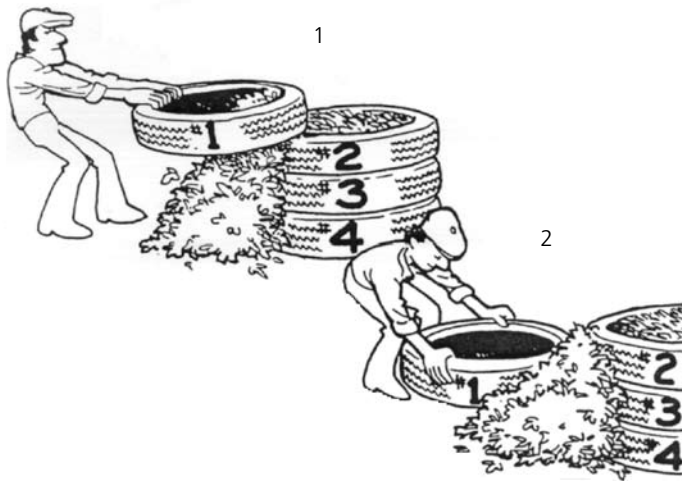

tip Place sticks between the tires to allow air flow and reduce odours.

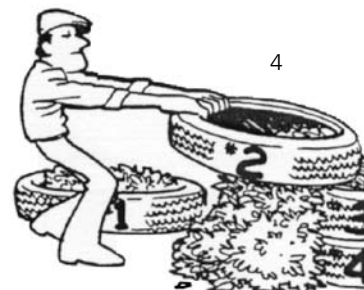

ROTATING BARREL COMPOSTER

A rotating barrel composter can reduce labour requirements for turning and aerating the composting materials. Most of them are limited in capacity due to the size of readily available barrels. They must be operated on a batch basis (no further materials added after a point in time) in order to produce finished compost. A number of small to very large commercially made barrel units are available that rotate either on their sides or end to end.

This particular side rotating barrel design makes use of a standard 45-imperial gallon size metal drum 34-3/4" in height. It is adapted from a design originally presented in *The Rodale Guide to Composting*, available at your local library.

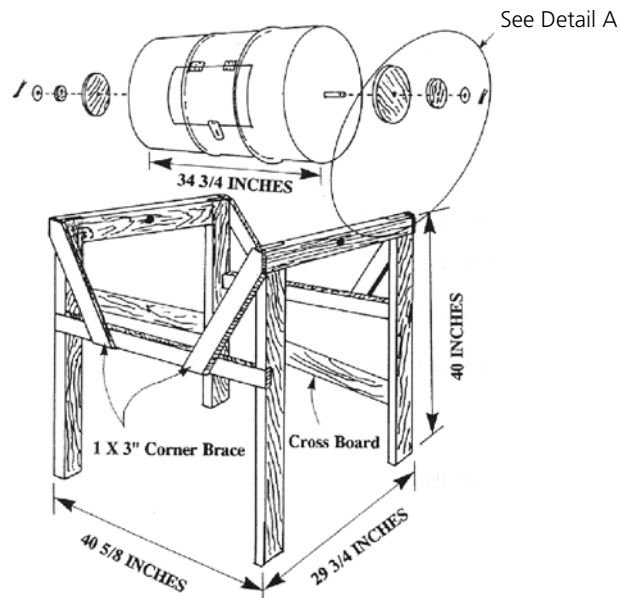

Specialized Tools

- drafting compass
- keyhole saw or motorized sabre saw
- metal file
- centre punch
- hammer and wood chisel
- 6" adjustable wrench
- hand or power drill with 1/2" spade bit and 1/4" and 3/16" bits

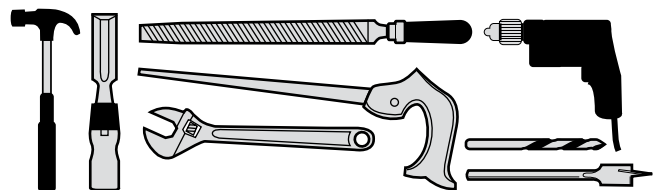

List of Materials

- 4 8' 2x4s
- 3 8' 1x3s
- 1 2' x 2' piece of $\frac{3}{4}$ " (19mm) plywood
- 2 1-1/2" x 2" galvanized butt hinges
- 1 small hasp
- 1 steel rod, $\frac{1}{2}$ " diameter by 42" long
- 1 45-imperial-gallon (205 litre) 'food grade' metal drum
- 8 $\frac{1}{4}$ " x 1-1/4" stove bolts c/w nuts
- 12 $\frac{1}{4}$ " x 1" stove bolts c/w nuts
- 28 1-1/2" galvanized No. 10 wood screws
- 2 $\frac{1}{2}$ " flat washers
- 3 1/8" x 1 $\frac{1}{2}$ " steel cotter pins
- carpenter's glue
- 1 litre flat black rust paint

Construction Sequence

1. Obtain a good 45-gallon drum that has not been used to hold any toxic chemicals. Those designated "food grade" are the best choice. If the barrel is metal, it should be unpainted on the inside and free of rust. Plastic barrels may also be used.

2. To accommodate the steel axial rod, a $\frac{1}{2}$ " hole must be drilled through the exact centre of the barrel at both ends. There are a number of ways of finding the centre of the top and bottom of a circular barrel. One simple method (see the illustration) is to use a carpenter's square to inscribe two right angles on the circular surface. The lines joining the ends of the right angles will intersect at the centre of the circle.

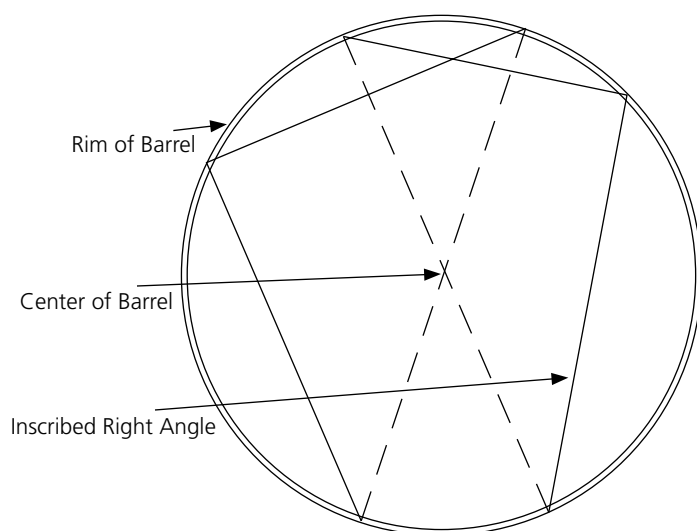

3. Mark the outline of the door opening on the outside of the barrel. The opening should be large enough (8"-10" x 16"-20" is good) to accommodate easy loading and unloading of material. For easier cutting, round the corners of the opening slightly. Drill a $\frac{1}{4}$ " hole on one of the lines to start the keyhole saw or sabre saw. If the door cuts across a rib on the barrel, a 1" vee notch must also be cut out on the rib to facilitate opening the door. Once the door has been cut out, re-attach it to the barrel using the hinges and hasp and the $\frac{1}{4}$ " x 1" stove bolts.

4. For ventilation, drill several rows of $\frac{1}{4}$ " holes into the barrel on the side opposite the door. To aid in heat retention, paint the entire outside of the unit with a flat black rust paint.

5. On the $\frac{3}{4}$ " piece of plywood, scribe and cut out two pieces 7-1/2" in diameter and two 2-3/4" in diameter. Drill a $\frac{1}{2}$ " hole through the centre of each. Centre and glue each small circle to its larger counterpart. Slipping each set of circles temporarily over the $\frac{1}{2}$ " steel rod prior to gluing will ensure that they will remain centered. After the glue has dried, attach the large circles to the ends of the barrel, as illustrated, with four $\frac{1}{4}$ " x 1-1/4" stove bolts per circle. Keep all the holes aligned.

6. File down each end of the steel rod by $\frac{1}{2}$ " to provide two flat parallel surfaces for drilling. Drill a $\frac{3}{16}$ " hole in each flattened end of the rod. Centre punching the holes first will make them easier to drill.

7. For the support frame, take a 8' 2x4s and cut 4 pieces 40" long for the uprights, 2 pieces 29-3/4" long for the frame horizontal pieces and 2 pieces 27" long for the crossboards. On the horizontal pieces, drill a 1/2" hole in the exact centre of the board (14-7/8" from each end) to accommodate the steel rod. On the outer narrow side of the uprights, mark and chisel out horizontal dado cuts for 1x3 side bracing. Start these 23" up from the bottom. The cuts should be 2-1/2" wide by 3/4" deep.

8. Assemble the two ends of the frame as illustrated with glue and two 1-1/2" No. 10 screws per joint. Use a corner lap joint between the uprights and the frame horizontal pieces. For additional support, brace the two U-shaped ends with the cross boards set at an angle as shown. Pilot drill all screw holes with a 3/16" bit.

9. For the 1x3 side supports, cut 2 pieces 41" long and 4 pieces 23-3/4" long. Slip the steel rod through the wooden bearing pieces on the barrel and fit the barrel assembly through the holes on the support frame ends. Insert a washer and steel cotter pin through each end of the steel rod and bend back the pin to keep the barrel in place.

10. Stand up the end frames and insert and fasten the two 1x3 side braces to the dadoed uprights with glue and 1-1/2" No. 10 screws. Attach the corner braces in the same manner and trim the ends to fit. Pilot drill all No. 10 screw holes with a 3/16" bit.

11. In order to keep material properly turning in the barrel and not sliding along the bottom as it is rotated, take one or two remaining 2x4 scrap pieces, cut them to fit and wedge them into the barrel at an angle.

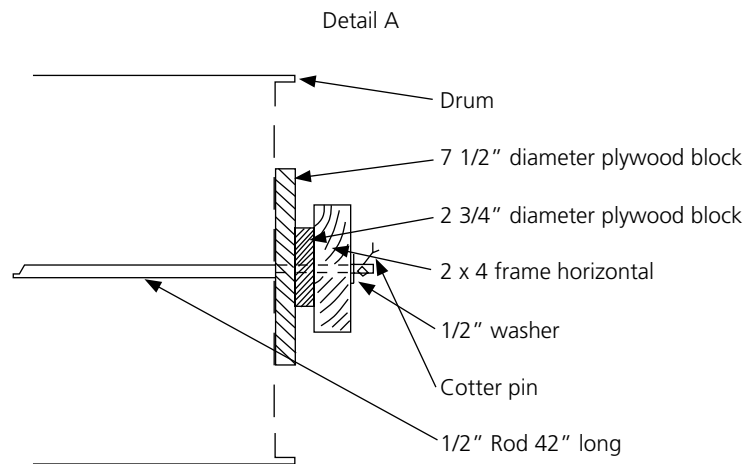

tip

Look for an Olive barrel at the ethnic marketplace or a soap barrel at your local car wash.

1-2-3 WORM COMPOSTER

Mary Appelhof’s 1-2-3 worm bin (1 foot high x 2 feet wide x 3 feet long) is sized to provide sufficient surface area to handle the food wastes from an average family of four to six people.

This version of the 1-2-3 bin is adapted from a design sheet developed by the King County, Washington Solid Waste Division.

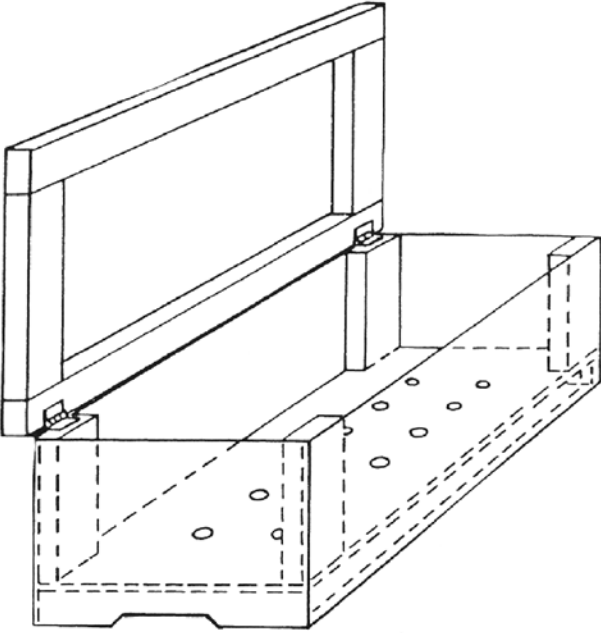

Specialized Tools

- hand or power drill with a 1/2" spade bit

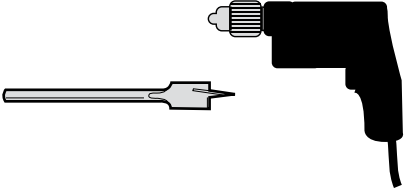

List of Materials

- 1 4' x 8' sheet of 1/2" (13 mm) plywood
- 1 12' 2x4, and one 16' 2x4 or four 8' 2x4s
- 2 lbs of 2" galvanized nails
- 1/2 lb of 3-1/2" galvanized nails
- 2 galvanized butt door hinges
- paraffin wax or marine varnish
- bathroom silicone sealant

Construction Sequence

1. Measure and cut the 4' x 8' sheet as indicated in the plywood illustration. Cut the 12 foot 2x4 into five pieces: two at 39", two at 23" and one 20" long. Using simple butt joints, nail the 2x4 pieces together on edge to form the base frame as illustrated. Use two 3-1/2" nails at each joint. Nail the plywood base piece onto the base frame. The end base frame boards can be notched for handholds.

2. For the sides, cut four 1-foot lengths out of the 16-foot 2x4. Nail a 1-foot 2x4 onto each end of the side panels flush with the top and side edges of the plywood. Nail the side pieces onto the base frame. Complete the box by nailing the end pieces onto the base and sides. Reinforce the box by ensuring that there is a nail staggered at least every three inches wherever plywood and 2x4s meet. For drainage, drill twelve 1/2" holes in the bottom of the box. In dry climates, reduce the number of holes, or eliminate them.

3. To construct the oversized lid, cut the 12-foot 2x4 into two 45" pieces and two 20" pieces. Arrange these into a rectangular frame with the short pieces on the inside as shown in the cut-away illustration. Centre the plywood top piece on the frame, allowing a 1-1/2" inset on all sides. Nail the plywood onto the 2x4s securely. Place and secure the hinges on the back side of the box on both upright 2x4s and on the under side of the frame so that the lid will stand upright when opened. To aid in this, short lengths of rope may also be attached to eye hooks screwed into the lid and the opposite uprights of the box when opened.

4. The inside surfaces of the bin that will be in contact with the moist bedding material can be safely made water-resistant with a coating of paraffin wax or a marine varnish. The joints can be sealed with a bathroom silicone sealant.

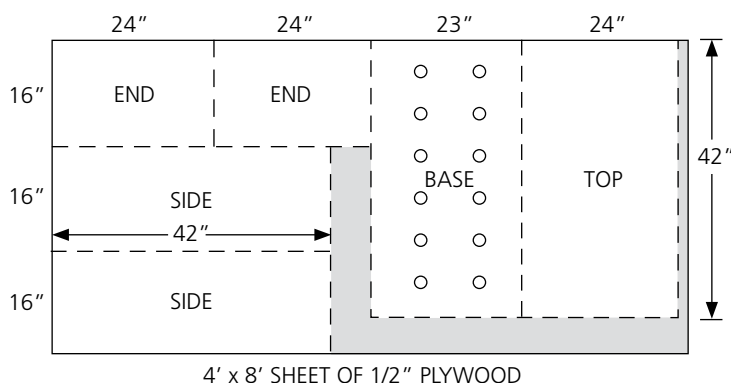

END BASE BOARDS CAN BE NOTCHED FOR HANDHOLDS

HOW DO I KNOW MY COMPOST IS READY TO USE?

Finished compost is dark in colour (like soil), crumbly (unlike original material) and smells like earth. Even though your compost pile may look ready to use, it may not be - microbial activity might still be occurring. If the compost is not finished, it will take nitrogen from the soil, making it briefly unavailable to plant material. This can result in nitrogen deficiency in your plants and will show up as stunted new growth and yellowing of older leaves. It can be corrected with an application of high-nitrogen liquid fertilizer

Here are two simple tests you can do to identify if your compost is finished.

Plastic Bag Test

Fill a re-sealable bag with your compost. Squeeze all the air out of the bag and seal. Let the bag sit for 24 hours. If there is air in the bag or smells awful, then the compost is still active and should not be applied to growing plants.

Jar Test

Fill a jar half full with compost. Add enough water to make it soggy. Seal it tight and let sit for one week. Then carefully open the jar and use your nose. If it smells like wet earth then the compost is ready. If it smells awful, then the compost should age a bit longer.

HARVESTING YOUR COMPOST

If you compost using a single bin design the finished compost will fall to the bottom of the unit. To access the finished compost simply remove the unfinished material from the top of the pile and set it aside. The finished compost can then be taken out.

Sift compost through a 7 – 21 mm (1/2 inch) metal screening for use as a lawn top dressing or in a potting soil mix. Materials that are sifted out can be put back into your compost bin.

note

Portable bins (pages 8-10) make getting to your finished compost easy. Simply undo the corners and move the bin to a new location. After moving unfinished material back into the bin you will be left with a pile of finished compost on the ground.

tip

Harvesting is conveniently done in autumn when dried leaves are abundant. Use yard trimmings and leaves as a base for your new pile and add your kitchen scraps all winter. Keep the pile moist in summer and you'll have beautiful compost by fall. You can dig it in then, or let it age until spring planting time.



Questions?

Waste Hotline:
780-496-5678

Email:
wasteman@edmonton.ca

Web:
www.edmonton.ca/waste

TTY:
780-944-5555

